

MTD_LabVIEW_Matlab

Where To Find This Example

Select **Help > Open Examples...** from the menus and type either the example name listed above or one of the keywords below.

Or in Version 13 or higher you can open the project directly from this page using this button. Make sure to select the **Enable Guided Help** before clicking this button.

Open Install Example

Design Notes

VSS/LabVIEW Integration Example

This example illustrates co-simulation with LabVIEW and MATLAB® in VSS. Co-simulation with LabVIEW is achieved by implementing the required functionality into a LabVIEW Virtual Instrument (VI); the Matlab implementation is done through a .m file.

In this example, a Moving Target Detector (MTD), used in Radar systems, is implemented as described below and the results are compared:

- The VSS implementation: uses the VSS native block MTD. This block is part of the VSS Radar Library.
- LabVIEW implementation: uses MTD.vi. This VI is implemented by using basic LabVIEW functionality. Requires an installation of LabVIEW Development Environment (32- or 64-bit).
- LabVIEW Mathscript implementation: uses MTD_MathScript.vi. Requires an installation of LabVIEW 32-bit Development Environment with the LabVIEW MathScript RT add-on module (the latter is available only for 32-bit installations of LabVIEW). Mathscript is a native compiler for .m files developed in MATLAB® or GNU Octave software.
- MATLAB implementation: uses MTD.m. This implementation requires an installation of MATLAB® software.

In this project, the same input signal is passed through the VSS MTD block, the LABVIEW block running the MTD.vi, the LABVIEW block running MTD_MathScript.vi and the MATLAB block calling the MTD.m function. The outputs are plotted and compared to verify they are all identical.

Note 1: This example will not run using the LabVIEW Run-Time Environment since the LabVIEW MathScript RT add-on module is not compatible with it.

Note 2: To link to the appropriate LabVIEW version, the variable TCPSPORT in the LABVIEW blocks should match the setting of TCP/IP Port in LabVIEW Tools/Options.../VI Server.

System Diagram - System Diagram 1

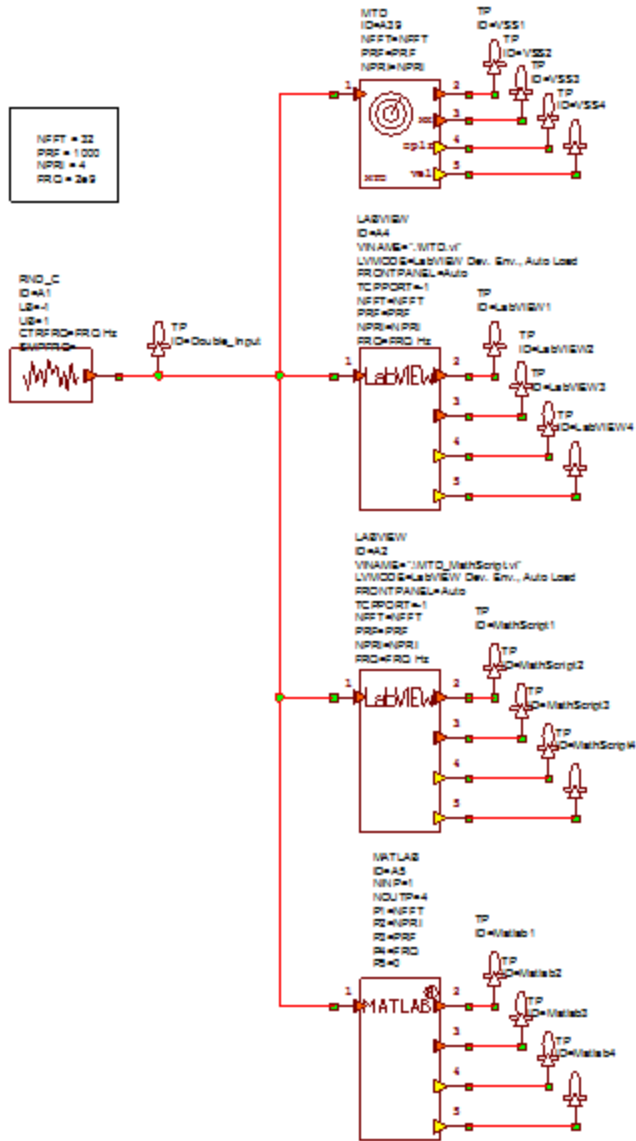

Graph - MTD Output

Re(WVFM(TP.VSS1, 128.0,1,0.5,0,0,0)) (ns) System Diagram 1 Time	Re(WVFM(TP.VSS1, 128.0,1,0.5,0,0,0)) System Diagram 1 y Values (No Data)	Re(WVFM(TP.MathScript1, 128.0,1,0,0,0,0,0)) (ns) System Diagram 1 Time	Re(WVFM(TP.MathScript1, 128.0,1,0,0,0,0,0)) System Diagram 1 y Values (No Data)	Re(WVFM(TP.Matlab1, 128.0,1,0,0,0,0,0)) (ns) System Diagram 1 Time	Re(WVFM(TP.Matlab1, 128.0,1,0,0,0,0,0)) System Diagram 1 y Values (No Data)	Re(WVFM(TP.LabVIEW1, 128.0,1,0.5,0,0,0)) (ns) System Diagram 1 Time	Re(WVFM(TP.LabVIEW1, 128.0,1,0.5,0,0,0)) System Diagram 1 y Values (No Data)
---	--	--	---	--	---	---	--

Graph - MTD Max

Re(WVFM(TP.VSS2, 4,0,1,0,5,0,0,0)) (ns) System Diagram 1 Time	Re(WVFM(TP.VSS2, 4,0,1,0,5,0,0,0)) System Diagram 1 y Values (No Data)	Re(WVFM(TP.MathScript2, 4,0,1,0,0,0,0,0)) (ns) System Diagram 1 Time	Re(WVFM(TP.MathScript2, 4,0,1,0,0,0,0,0)) System Diagram 1 y Values (No Data)	Re(WVFM(TP.Matlab2, 4,0,1,0,0,0,0,0)) (ns) System Diagram 1 Time	Re(WVFM(TP.Matlab2, 4,0,1,0,0,0,0,0)) System Diagram 1 y Values (No Data)	Re(WVFM(TP.LabVIEW2, 4,0,1,0,5,0,0,0)) (ns) System Diagram 1 Time	Re(WVFM(TP.LabVIEW2, 4,0,1,0,5,0,0,0)) System Diagram 1 y Values (No Data)
---	--	--	---	--	---	---	--

Graph - Doppler Offset

Re(WVFM(TP.VSS3, 4,0,1,0,5,0,0,0)) (ns) System Diagram 1 Time	Re(WVFM(TP.VSS3, 4,0,1,0,5,0,0,0)) System Diagram 1 y Values (No Data)	Re(WVFM(TP.MathScript3, 4,0,1,0,0,0,0,0)) (ns) System Diagram 1 Time	Re(WVFM(TP.MathScript3, 4,0,1,0,0,0,0,0)) System Diagram 1 y Values (No Data)	Re(WVFM(TP.Matlab3, 4,0,1,0,0,0,0,0)) (ns) System Diagram 1 Time	Re(WVFM(TP.Matlab3, 4,0,1,0,0,0,0,0)) System Diagram 1 y Values (No Data)	Re(WVFM(TP.LabVIEW3, 4,0,1,0,5,0,0,0)) (ns) System Diagram 1 Time	Re(WVFM(TP.LabVIEW3, 4,0,1,0,5,0,0,0)) System Diagram 1 y Values (No Data)
---	--	--	---	--	---	---	--

Graph - MTD Output Comparison

